

Copyright 2011 by Z. Miller

COMPANION WEBSITES: <http://www.analemma.com/>
<http://www.stellarium.org/>

INTRODUCTION:

When viewing the sky, an earthbound observer can appreciate daily, monthly, and annual changes in the sun's position – what is termed the **sun's apparent motion** – all of which occur in predictable cyclic manner. These changes are caused by three key principles:

- The earth rotates on its axis – causing day and night.
- The earth revolves around the sun in approximately 365 days – creating our year.
- The earth's axis is tilted at 23.5° with respect to the plane of its revolution around the sun.

However, knowing these facts is not enough to allow an amateur astronomer (you) to make accurate solar predictions. Instead, making predictions of the sun requires careful practice observing its varying position. In this activity, you will work to gain comfort using your “theatre of the mind” (your imagination) to visualize changes we observe about the sun with the aid of a computer animation. You will also learn and apply new terms associated with our “celestial sphere” — the term used to describe our view of the sky during the day or night. For this activity, consider your computer an interactive private planetarium to accomplish these goals. Get ready to stretch your brain!

TERMS TO KNOW:

Celestial Sphere _____

Altitude [of a celestial object] _____

Zenith _____

Meridian _____

Celestial Equator _____

DIRECTIONS:

As you work through this activity you'll notice a box, , at the start of many paragraphs and sentences. That box is there for you to check off once you've read and understood the content that follows it. Doing so will help you keep your place on the worksheet as your attention moves back and forth between your computer screen, your instructions, and your answer sheet. This symbol **◆** indicates that you must record an answer on your answer sheet. Be sure to keep in mind that the numbered directions below correspond to the numbers shown in the accompanying diagrams.

PROCEDURE:

Open up the following interactive animation:

<http://astro.unl.edu/classaction/animations/coordsmotion/sunmotions.html>

Take a few minutes noting that *everything* in this interactive tool is “clickable”. Meaning, you grab and manipulate the sun (see the yellow line within the celestial sphere), the various menu settings, and the orientation of the celestial sphere viewing it from any direction.

IMPORTANT NOTE: In some cases, significant solar calendar dates (i.e., solstice and equinox dates) are shown below in a “single date format” – these celestial events can vary by +/- 1-day depending upon the year of study. For example, the winter solstice is on December 22 in 2011, while it is on December 21 in 2012. For simplicity, the first of the two possible dates (i.e., December 21st) is shown for most questions below.

IMPORTANT NOTES:

- Click the refresh button on your browser to reset all of the settings you may have changed during the last few minutes.
- Tech' Tip: You can change the time of day within the celestial sphere by either dragging the sun, or clicking and dragging the hour/minute hands on the clock.

1. Enter the day of the year **December 21st**.
2. Enter the time of day **8:00am** (it may be easiest for you to type the time rather than having to use the mouse).
3. Enter the latitude for your location by typing or dragging the latitude line on the map (**41.0° North Latitude** is the approximate latitude for lower New York). If needed, use p. 2 of the Earth Science Reference Tables (ESRTs) to determine your latitude.
4. Uncheck the **ecliptic** option.
5. Set the animation speed to **2.0 hrs/sec**.
6. Rotate the celestial sphere so that you are looking *from* the southwest. Your celestial sphere should match **Fig. 2**.
7. Now, click **start animation** and allow approximately three to four days to elapse. Watch as the sun moves causing our day and night in this early winter snapshot.

Your answers to questions 8 through 12 are to be recorded in Table 1 below.

8. In what compass direction would you look to see the sun *rise* on December 21st?
9. In what compass direction would you look to see the sun *set* on December 21st?
10. What is the maximum altitude the sun reaches on December 21st? (Be sure to include units and Refer to Fig. 3 to help you — the answer is not 13.4°...☺)
11. In what compass direction would an observer face to view the sun at this highest altitude during its daily trek across our sky? (*Hint: don't forget adjectives, like "due"!*)

12. Repeat #2 through #11 instead using the dates March 20th and June 21st to complete Table 1 below.

Table 1: Solar Directional Data for An Observer in New York State

	Sun's Sunrise Viewing Direction	Sun's Sunset Viewing Direction	Sun's Solar Noon Viewing Direction	Solar Noon Altitude
December 21 st /22 nd				
March 20 th /21 st & September 22 nd /23 rd				
June 21 st /22 nd				

13. Referring to Fig. 2 on p. 1, and what term is used to describe the sun at its highest point each day? (*Hint: It may help you to also review #10 and #11.*)

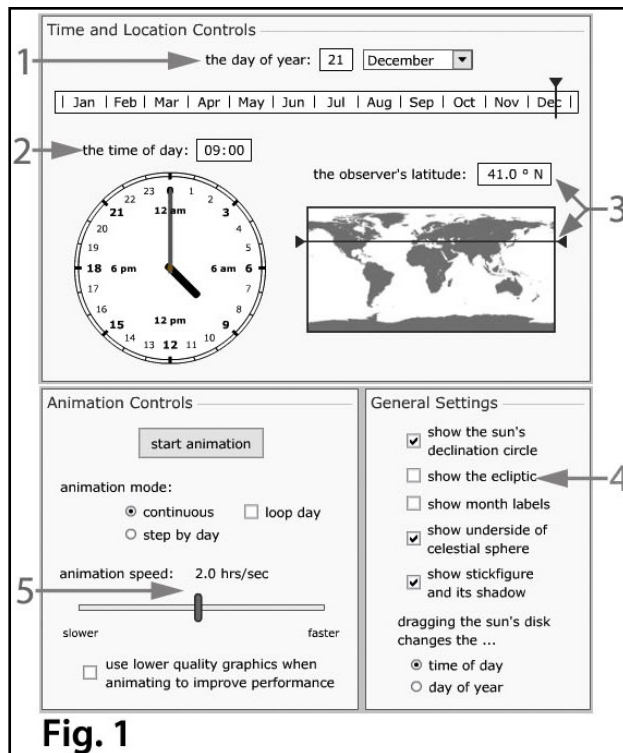

Fig. 1

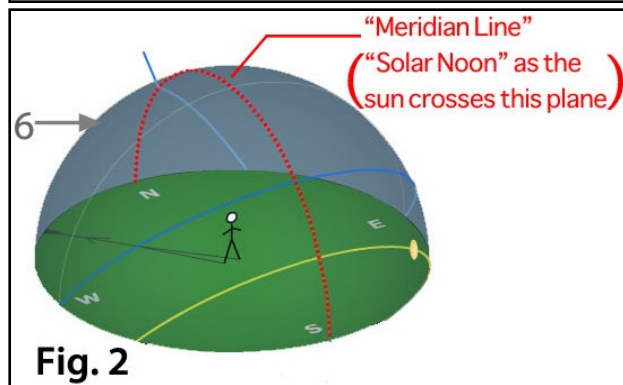

Fig. 2

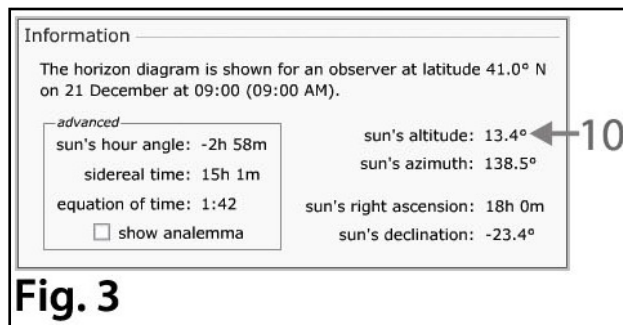
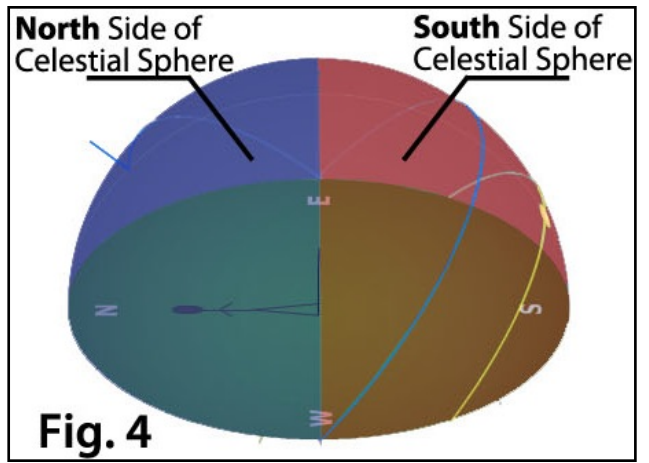

Fig. 3

_____ ?

Refer to Fig. 4 — the celestial sphere viewed from 41.0° North Latitude on December 21st — to answer #14.



14. For an observer in New York State, on December 21st, from sunrise, to solar noon, and ending with sunset, the winter sun passes through the observer's:

- a) northern sky
- b) southern sky
- c) both northern and southern sky

(Circle one.)

15. Considering your answer to #14 above, in which general direction does an observer's shadow (located in New York State) *always* point in the winter (choose one: northern side / southern side)?

_____ Explain why! _____

16. Refer to Table 1, and explain why an observer's shadow points in *both* the northern and southern direction during the course of an entire day on June 21st.

17. Write a brief hypothesis as to why this important daily "high point" of the sun's movement is referred to as "solar noon", and *not* simply "noon"? (*Hint 1: the time on your clock ("local time") is very rarely the same time as when "solar noon" occurs. Hint 2: be specific – there are many possible correct answers to this question. Try your best!*)

You will now focus how seasonal changes affect the sun when keeping the daily time constant (the same).

Set the animation to the following settings to match **Fig. 5**:

- Your local latitude (41.0° North Latitude is the approximate latitude for lower New York).
- Enter day of the year **December 21st**.
- 12pm, or noon. (In this case, this is a rare instance when solar noon matches up with clock noon.)
- You should be viewing the celestial sphere *from the west*.

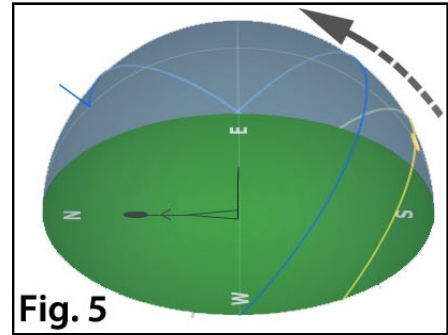

18. Change **animation mode** to **step by day** (Leave the default animation speed of “15 days/second”).

19. Click **start animation**. If done correctly, the sun should remain at solar noon (see the arrow in Fig. 5).

20. **Stop the animation** when the date reaches **June 21st**.

21. How does the altitude of the solar noon sun change from December 21st to June 21st?

22. The yellow line is the sun’s daily path. Based on the length of this line *above* the horizon, what happens to the length of daylight hours – termed the “**duration of insolation**” – from the period of December 21st to June 21st?

23. You likely already knew the answer to #22. Describe an example from your life in which you experienced this changing duration of insolation during *either* early winter (December 21st), or early summer (June 21st). (Hint: you could start with something similar to...”During the end of a school year, I notice the sun...”)

Your answers to questions 24 through 27 are to be recorded in Table 2 below.

24. What time (rounded to the nearest half-hour) does the sun *rise* on June 21st (include a.m./p.m.)?

25. What time (rounded to the nearest half-hour) does the sun *set* on June 21st (include a.m./p.m.)?

26. Using your answers to #24 and #25, what is the total duration of insolation an observer experiences on June 21st?

27. Repeat #24 *through* #26 for December 21st and March 20th to complete Table 2 below. (Don’t forget units!)

Table 2: Solar Time Data for An Observer in New York State

	Sunrise Time	Sunset Time	Duration of Insolation (Hours of Daylight)
December 21 st /22 nd			
March 20 th /21 st & September 22 nd /23 rd			
June 21 st /22 nd			

28. Does your answers to #22 agree with the data your data in Table 2 (yes / no) _____?

Explain your answer: _____

POST ASSESSMENT

The following questions may provide the most benefit if attempted without an animation or computer. Your answers to the above questions should provide enough information to answer the questions below correctly. Then, a completed seasonal celestial sphere diagram, or a computer animation, can be used to check your work.

Refer to Figure 6 to answer questions 29 and 30.

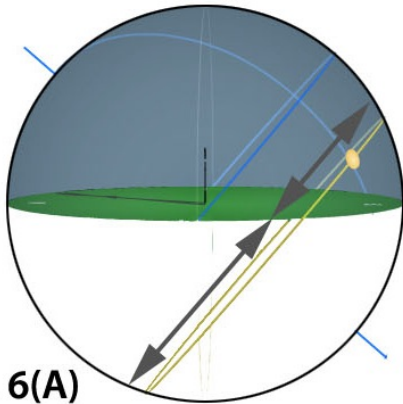

Fig. 6(A)

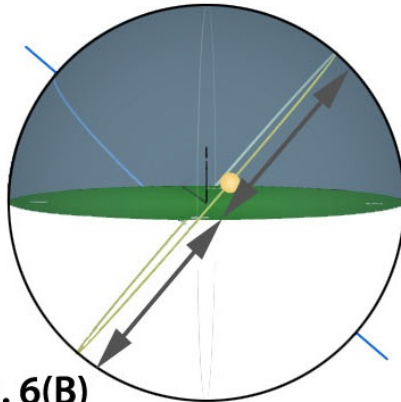

Fig. 6(B)

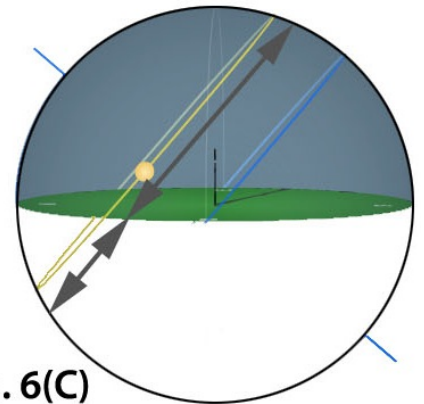

Fig. 6(C)

29. Examine the prefix “Eq” in the term **Equinox**. The equinox occurs on or about March 21st and September 22nd – as the sun’s direct rays pass over the equator (0° Latitude). These dates are “midpoints” in terms of the sun’s maximum and minimum solar noon altitude.
30. Which diagram represents the daily apparent path of the sun on an equinox?
(Hint: the arrows shown emphasize varying duration of insolation) (choose A, B, or C)

Explain! _____

Refer to Figure 7 to answer questions 31 through 34. Again, choose A, B, or C for #31 through #33.

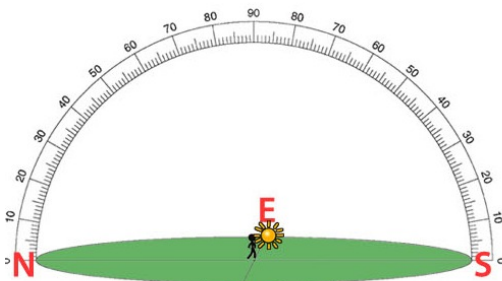

Fig. 7(A)

W

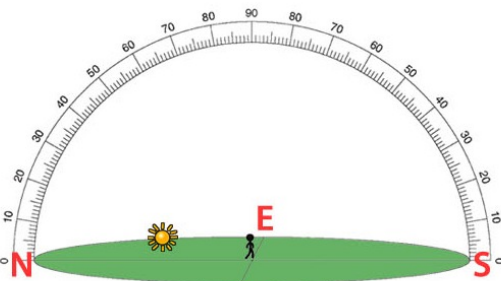

Fig. 7(B)

W

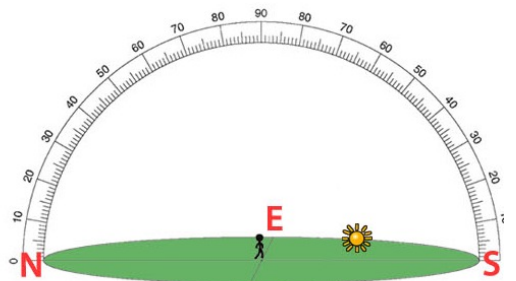

Fig. 7(C)

W

31. Which diagram shows a *rising* sun for an observer at 41.0° north latitude on December 21st _____?
32. Which diagram shows a *rising* sun for an observer at 41.0° north latitude on June 21st _____?
33. Which diagram shows a *rising* sun for an observer at 41.0° north latitude on September 22nd _____?
34. **Draw** the location of the setting sun for all three diagrams (7A, 7B, and 7C) along the western horizons.
(Hint: remember to keep in mind the location of the rising sun.)

REFLECTION

On this lab...I’ve learned/thought... _____
